



Wallpack with cutoff glare shield. All aluminum precision die cast construction with tempered glass lens. 30°. cutoff strip included. Lamp supplied.

Color: Bronze

Weight: 16.2 lbs

Project:	Type:
Prepared By:	Date:

Lamp Info		Ballast Info	
Type:	ED17	Type:	CWA-HPF QT
Watts:	150W	120V:	1.1/1.6A
Shape/Size:	N/A	208V:	.6/.9A
Base:	N/A	240V:	.5/.8A
ANSI:	N/A	277V:	.5/.7A
Hours:	10,000	Input Watts:	185W
Lamp Lumens:	12,500	Efficiency:	81%
Efficacy:	68 LPW		

Technical Specifications

Listings

UL Listing:

Suitable for wet locations. HID fixtures can be wired with 90°C supply wiring if supply wires are routed 3" away from ballast.

Construction

Housing:

Die cast aluminum, 1/2" NPS tapped holes top, both sides and back for conduit or photocontrol. Hinged refractor frame. Continuous silicone rubber gasket.

Reflector:

Specular anodized aluminum, removable for installation. Symmetrical light pattern maximizes distance between fixtures.

Cutoff Lens:

Tempered glass.

Finish:

Our environmentally friendly polyester powder coatings are formulated for high-durability and long-lasting color, and contains no VOC or toxic heavy metals.

Optical

Refractor:

Prismatic optics designed to minimize glare and throw light down and out. Heat resistant borosilicate glass.

Electrical

Quad Tap:

Fixture works with 120, 208, 240 and 277 Volts.

Dimensions

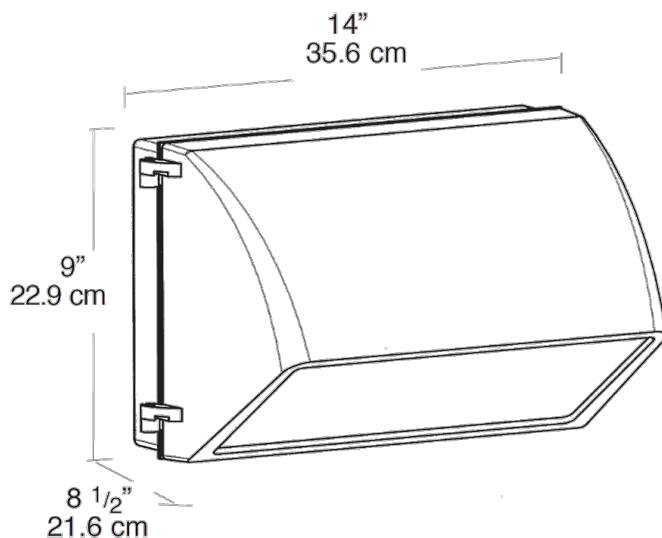

Features

- Precision die cast aluminum housing with durable polyester powder coating
- Tempered Glass Refractor and Tempered Glass Lens
- Drilling template for easy box mounting
- Silicone gasket remains in place during relamping
- Top, side and back conduit openings
- Cutoff Glare Shield for Friendly Lighting
- Long life lamp included