



Die cast aluminum one piece guard with distinctive flat bottom for contemporary look. Machined threads for smooth fit. A headless set screw is provided to lock guard in place.

Color: Natural

Weight: 0.4 lbs

<b>Project:</b>	<b>Type:</b>
<b>Prepared By:</b>	<b>Date:</b>

**Technical Specifications**

**Listings**

**UL Listing:**

Suitable for wet locations when used with RAB Vapor proof fixtures.

**Other**

**Die Cast Guards:**

One pieced die cast aluminum. Set screw locks guard in place. Also a wire clamp guard is available.

**Country of Origin:**

Designed by RAB in New Jersey and assembled in Taiwan.

**Trade Agreements Act Compliant:**

This product is a product of Taiwan and a "designated country" end product that complies with the Trade Agreements Act.

**GSA Schedule:**

Suitable in accordance with FAR Subpart 25.4.

**Construction**

**Wire Clamp Guards:**

No. 8 gauge steel wire rod welded to clamping band with captive clamping screw.

**Dimensions**

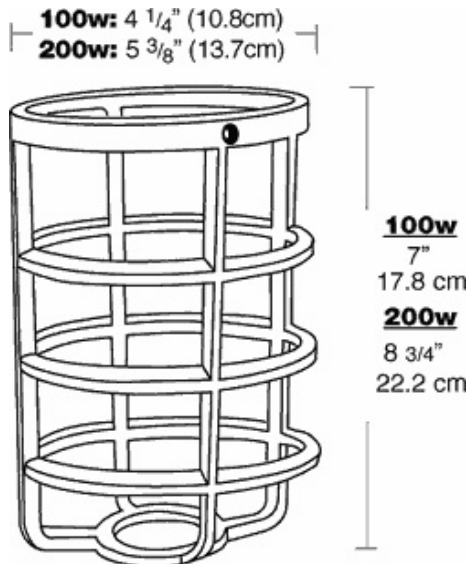

**Features**

- Set screw locks guard in place
- Machined threads for smooth running fit on Vaporproof fixtures
- Heavy, one-piece aluminum die casting
- Captive clamping screw won't fall out
- Threaded aluminum ring secures reflector to fixture