

# HAZSLED80FB-G



Stanchion Mount HAZLED is a Class I, Division 2 LED fixture designed with 60 years of experience in hazardous location lighting.

Color: Gray

Weight: 17.3 lbs

**Project:**

**Type:**

**Prepared By:**

**Date:**

### Driver Info

Type:	Constant Current
120V:	0.68A
208V:	0.40A
240V:	0.35A
277V:	0.3A
Input Watts:	81W
Efficiency:	98%

### LED Info

Watts:	80W
Color Temp:	5000K
Color Accuracy:	N/A
L70 Lifespan:	100000
Lumens:	N/A
Efficacy:	0 LPW

## Technical Specifications

### LED Characteristics

#### \*Photometrics:

Lumens and CRI not available for HAZLED with color globes.

#### LEDs:

Multi-chip, high-output, long-life LEDs

#### Lifespan:

100,000-hour LED lifespan based on IES LM-80 results and TM-21 calculations.

#### Color Stability:

LED color temperature is warranted to shift no more than 200K in CCT over a 5 year period.

#### Color Uniformity:

RAB's range of CCT (Correlated Color Temperature) follows the guidelines of the American National Standard for Specifications for the Chromaticity of Solid State Lighting (SSL) Products, ANSI C78.377-2011.

### Hazardous Location Classifications

#### UL 844:

Electric lighting fixtures for use in hazardous (classified) locations

#### UL 1598:

Electric lighting fixtures for use in non-hazardous locations

#### UL 8750:

Light Emitting Diode (LED) Light Sources for Use in Lighting Products

### Hazardous Location Classifications:

Class I: A hazardous location in which flammable gases or vapors may be present in the air in sufficient quantities to be explosive or ignitable, such as petroleum refineries, aircraft hangars, dry cleaning plants, utility gas plants or storage areas for liquified petroleum or natural gas, and spray finishing areas.

Division 2: Abnormal condition, where ignitable concentrations of flammable gases, vapors or liquids are not like to exist under normal operating conditions, for example:

Closed storage drums containing flammable liquids in an inside storage room would not normally allow the hazardous vapors to escape into the atmosphere. But if one of the containers is leaking, you've got an abnormal condition.

Groups A - D: The gases and vapors of Class 1 locations are broken into four groups by the Code: A, B, C, and D. These materials are grouped according to the ignition temperature of the substance, its explosion pressure, and other flammable characteristics.

Group A - The only substance in group A is acetylene because it is a gas with extremely high explosion pressures.

Group B - This group includes hydrogen and other materials with similar characteristics.

Group C & D - The most usual Class 1 groups. They comprise the greatest percentage of all Class I hazardous locations. Found in Group C is ethylene.

Found in Group D are many of the most common flammable substances such as butane, propane, natural gas and propane.

### Electrical

#### Driver:

Constant Current, Class 2, 100-277V, 50/60 Hz, 2000mA, THD <20%

#### Construction

#### Minimum Starting Temperature:

-40°C

#### Maximum Ambient Temperature:

Suitable for use in 55°C (131°F) ambient temperatures.

#### IP Rating:

Ingress Protection rating of IP66 for dust and water.

#### Thermal Management:

Superior heat sinking with external Air-Flow fins

#### Housing:

Die-cast aluminum housing, lens frame and mounting arm

#### Hardware:

All external hardware is stainless steel

#### Reflector:

Semi-specular aluminum

#### Lens/Globes:

Clear flat glass lens

### Mounting:

Stanchion mounting to 1 1/2" stanchion

### Gaskets:

Closed cell silicone gasket

### Finish:

Our environmentally friendly polyester powder coatings are formulated for high-durability and long-lasting color, and contain no VOC or toxic heavy metals.

### Green Technology:

Mercury and UV free. RoHS compliant components. Polyester powder coat finish formulated without the use of VOC or toxic heavy metals.

### Other

#### Replacement:

The HAZLED 80W replaces 150W Metal Halide.

#### Country of Origin:

Designed by RAB in New Jersey and assembled in the USA by RAB's IBEW Local 3 workers.

#### Buy American Act Compliant:

This product is a COTS item manufactured in the United States, and is compliant with the Buy American Act.

#### Recovery Act (ARRA) Compliant:

This product complies with the 52.225-21 "Required Use of American Iron, Steel, and Manufactured Goods-- Buy American Act-- Construction Materials (October 2010).

## Technical Specifications (continued)

### Other

#### Trade Agreements Act Compliant:

This product is a COTS item manufactured in the United States, and is compliant with the Trade Agreements Act.

### GSA Schedule:

Suitable in accordance with FAR Subpart 25.4.

### Listings

#### IESNA LM-79 & LM-80 Testing:

RAB LED luminaires have been tested by an independent laboratory in accordance with IESNA LM-79 and LM-80, and have received the Department of Energy "Lighting Facts" label.

## Dimensions

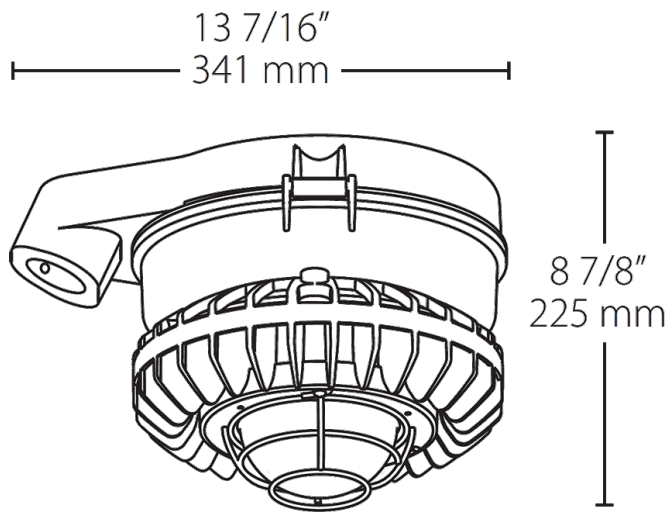

## Features

- Class 1, Division 2, Groups A, B, C, D
- IP66, UL1598, UL8750 and UL 844 ratings
- Resistant to shock and vibration
- Rugged construction ensures long-life and safe operation
- 100,000-Hour LED lifespan
- 5-Year, no-compromise warranty