

Project:

Type:

Prepared By:

Date:



UPC: 19813748894



Features and Benefits

HID REPLACEMENT - Replace conventional HID lamps

BALLAST BYPASS - Internal driver eliminates the need for external driver or ballast

50,000-HOUR LIFESPAN - Lasts 25x the life of conventional HID lamps

ENERGY SAVINGS - Uses 76% less energy than traditional lamps

HEAT DISSIPATION - Thermal technology extends lifespan

WATER & DUST RESISTANT - Ideal for warehouse applications

ENCLOSED FIXTURE RATED - May be used in enclosed and open fixtures

UPLIGHTING - Ring of LEDs provides 10% uplighting to eliminate "cave effect"

MERCURY FREE - Environmentally friendly

SURGE PROTECTION - Includes 4kV surge protection

SENSOR PORT - Lamp top has a low-voltage AUX port for lamp level sensor controls - refer to HID replacement accessories for sensor product numbers

Technical Specifications

Product Type	HID
Bulb Shape	High Bay
Wattage	60W
Wattage Equivalency	200W HID
Typical Lumen Output	8000
Efficacy	133 lm/W
Color Temperature	4000K Cool White
CRI	80
Base Type	EX39
L70 Lifespan	50,000 hours
Operating Temperature	-30°C - 60°C
Dimmable	No
Beam Angle	120°
Warranty	5-Year, No-Compromise Warranty
Installation Type	Type B, Ballast Bypass
Installation Orientation	Vertical
For Use in Emergency Fixtures	No

Electrical Characteristics

Input Voltage	100-277V
Power Factor	>0.9
Operating Frequency	50 / 60 Hz
Input Current @ 120V	0.67mA
Flicker	<30%
THDi	<20%

Listings

UL Listed	Yes
UL Classified	Yes
DLC Listed	This product is on the Design Lights Consortium (DLC) Qualified Products List and is eligible for rebates from DLC Member Utilities.
DLC Model Number	H20007
DLC Product Code	PQ6WX73R
CEC Status	Lawful for sale in California

Light Distribution

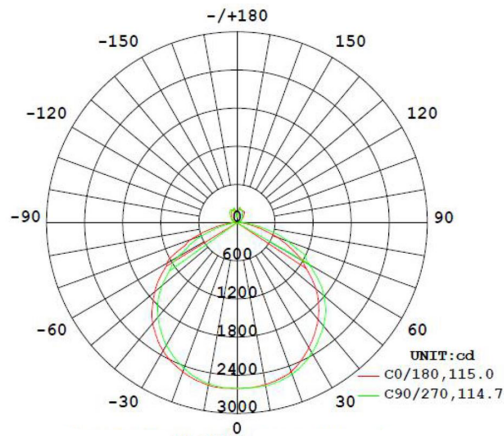

Minimum Compartment Size

Length x Width x Height [mm]	Lamp Quantity
7.9 x 7.9 x 8.3	1

Case and Pallet Dimensions

	QTY	LENGTH	WIDTH	HEIGHT
CASE	4	15.4	15.4	8.8
PALLET	30	32.7	32.7	39.8

Wiring Diagram

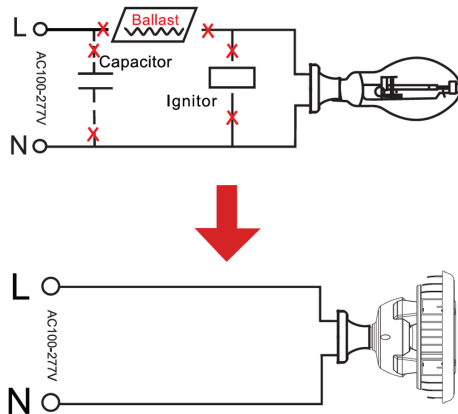

Dimension

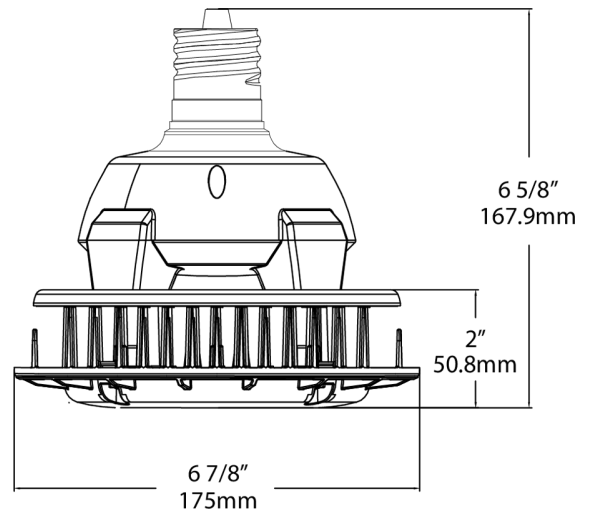

Sensor Installation

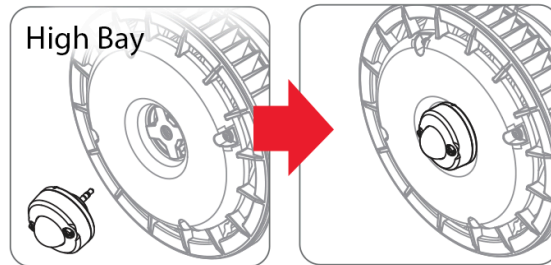
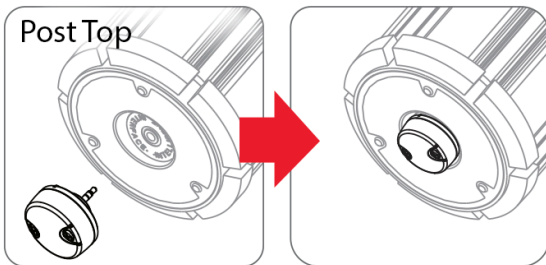

Compatible with:

HID-80-EX39-8xx-BYP-PT
 HID-100-EX39-8xx-BYP-PT
 HID-120-EX39-8xx-BYP-PT

Compatible with:

HID-60-V-EX39-8xx-BYP-HB
 HID-80-V-EX39-8xx-BYP-HB
 HID-115-V-EX39-8xx-BYP-HB